



APPROVAL SHEET

BRAND	The logo for Winpow A+, featuring the word "WINPOW" in yellow and "A+" in red, with a globe icon behind it.
PRODUCT	3.0V LITHIUM-MANGANESE BUTTON CELL
MODEL	CR2016 (70mAh)
PREPARED BY	
APPROVED BY	
DATE	AUG., 2016



WINPOW(HK) COMPANY LIMITED

1. 【SCOPE】

This specification applies to the following 3.0v lithium button cell CR2016 made by WINPOW(HK) COMPANY LIMITED / HUIZHOU WINPOW ELECTRONIC CO.,LTD.

2. 【RATINGS】

TABLE I :

ITEM		UNIT	SPECIFICATIONS	CONDITIONS
Nominal voltage		V	3.0	
Nominal capacity		mAh	70	Standard discharge with load 30kΩ
Instantaneous short-circuit current		mA	≥200	Time≤0.5 second
Off-load voltage		V	≥3.2	
Operating temperature		℃	-20~60	
Standard weight		g	1.72	Unit cell
Service output	Initial	Standard	70 h	Continuous discharge with load 3kΩ, till 2.0v end-voltage
	After 12 months storage	Standard	68 h	

TABLE II :

ITEM	CONDITIONS	CHARACTERISTICS	
		Standard	70 mAh
Thermal durability	Kept for 20 days at 60℃±3℃, then continuously discharge with 15kΩ load till 2.0v end-voltage	Standard	70 mAh
Self-discharge rate	Stored for 12 months at normal temperature and humidity	≤5%	

3. 【PERFORMANCE AND TEST METHODS】

Unless otherwise stated, all the testing is carried out under the condition: environmental temperature, 20℃~25℃; environmental humidity, 65±20%. Please refer to Table III

4. 【SUGGESTIONS AND CAUTIONS】

- 4.1 Install batteries correctly.
- 4.2 Ensure the contact points to be clean and conductive.
- 4.3 Do not mix different types, different brands batteries to serve together.
- 4.4 Do not heat, recharge the batteries.
- 4.5 Do not dispose of the batteries in fire.
- 4.6 Keep away from the small children, if swallowed promptly see doctor.
- 4.7 Pay attention to the producing date.

TABLE III:

No	ITEM	TEST METHODS	STANDARD	
			Diameter	Height
1	Dimensions	Using vernier caliper (accuracy ≥ 0.02) while avoiding short-circuit	Diameter	20.0 (-0.2) mm
			Height	1.65(-0.2) mm
2	Off-load voltage	Using multimeter (accuracy $\geq 0.25\%$) internal resistance $\geq 1M\Omega$	≥ 3.2 v	
3	Instantaneous short-circuit current	Time of short-circuit should be less than 0.5 second and avoid repeated test within half an hour	≥ 200 mA	
4	Appearance	Eyeballing	Bright, clean, no rust, no leakage, And no flaw	
5	Capacity	Continuously discharge for 8 hours with load $30k\Omega$, temperature at $20\sim 25^{\circ}C$, humidity at $65\pm 20\%$ till 2.0v end-voltage (for fresh battery only: within 3 months)	≥ 70 mA h	
6	Vibration test	Put battery on the platform of the vibrations machine, start the machine and adjust the frequency form 10 times per minute to 15 times per minute. keep it running for an hour	Characteristics keep stability	
7	Leakage at high temperature test	Stored under temperature ($60^{\circ}C$) for 7 days	No leakage allowed	
8	Over discharge Test	After 2.0v end-voltage, continuously discharged for 5 hours	No leakage allowed	

5. 【CUTAWAY DIAGRAM OF 3.0V LITHIUM MANGANESE DIOXIDE BUTTON CELL】

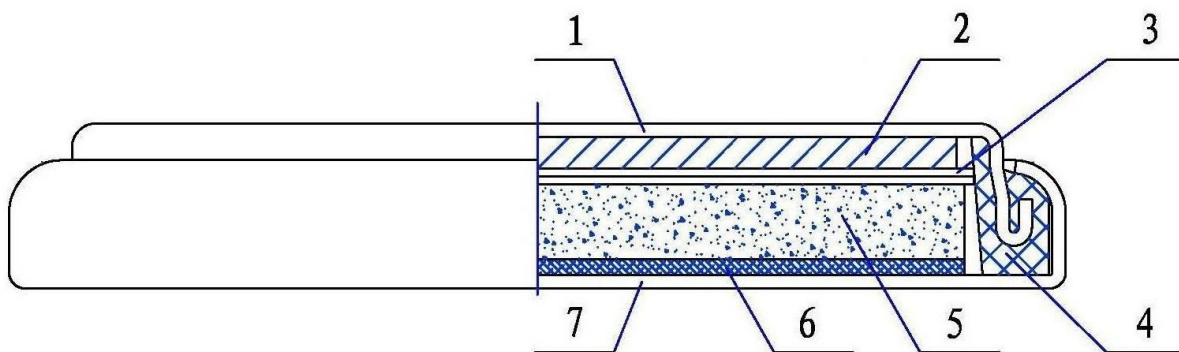

- 1、Cathode Shell 2、Cathode (slice of lithium) 3、Septum 4、Gasket
 5、Anode (MnO_2) 6、Anode collector net 7、Anode shell



6. 【DISCHARGE CHARACTERISTICS】

